

ANSI/SPRI/GT-1 TEST PRESSURES UP TO 136 PSF(VERTICAL) , AND 223 PSF (HORIZONTAL)

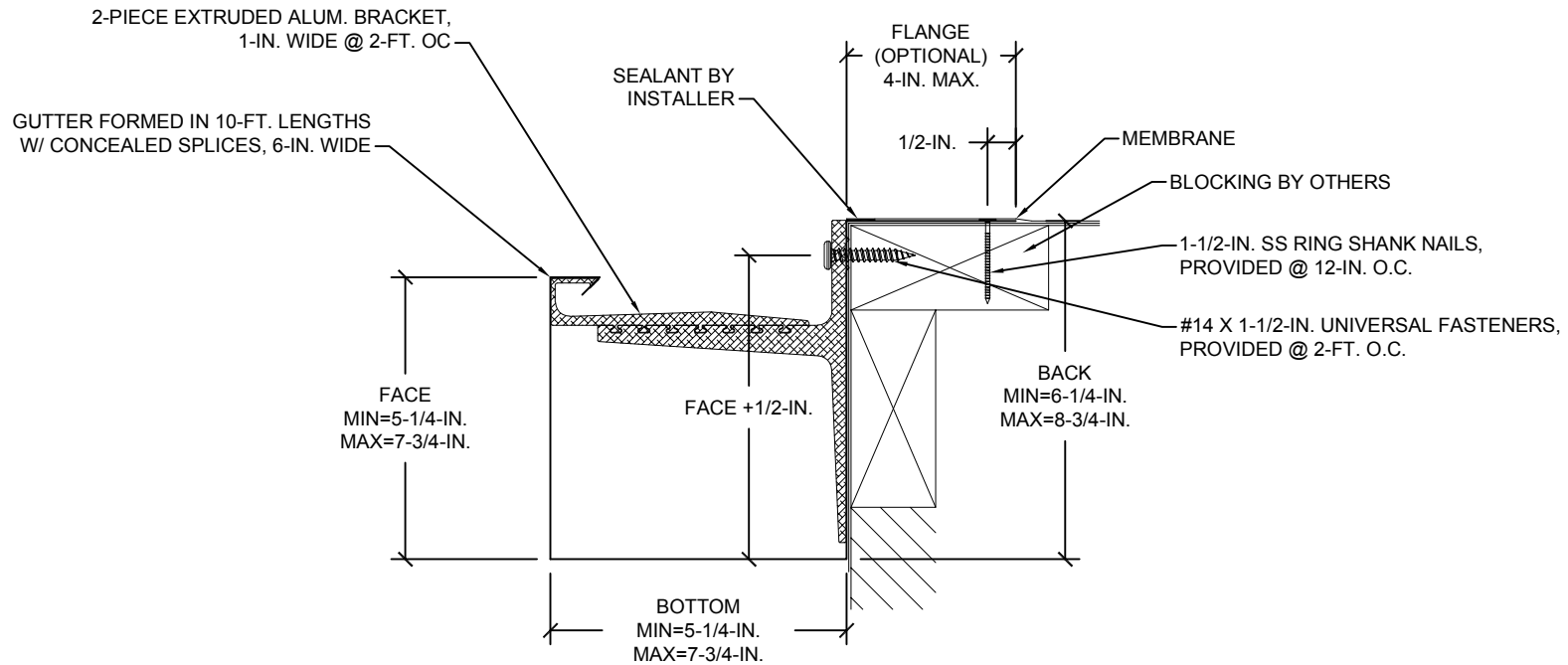

BOTTOM SIZES ARE PROVIDED IN 1/2-IN. INCREMENTS
(e.g. 5-1/4-IN., 5-3/4-IN., 6-1/4-IN.,)

FOR MASONRY APPLICATIONS, PLEASE CONTACT OMG.

CONTACT OMG FOR APPROPRIATE RECOMMENDATIONS NEEDED TO MEET/EXCEED
ANSI/SPRI/GT-1 DESIGN CRITERIA

APPLICATIONS
SINGLE-PLY MEMBRANES
MOD BIT
BUR

SIZES:
SEE DRAWING

NOTES:
1-REFER TO ROOF MEMBRANE MANUFACTURER FOR
THEIR APPROVED INSTALLATION DETAIL.
2-TESTED IN ACCORDANCE WITH ANSI/SPRI/GT-1.

ANSI/SPRI GT-1 TESTED



		OMG Inc. 4 Commerce Way Arden, NC 28704 828-676-1700 www.omgroofing.com	
NAME: WIND RESISTANT BOX GUTTER			
DRWN. BY: PL	DATE: 03/10/2020	SKU:	
APPD. BY: KP	DATE: 03/10/2020	SCALE: NOT TO SCALE	SHEET: 1 OF 1